

# MENUMASTER<sup>®</sup> Commercial

Project #: \_\_\_\_\_

Item #: \_\_\_\_\_



Model RMS510D shown

## Low Volume

This category of microwave is ideal for...

### Applications:

- Vending
- Break rooms
- Espresso bars
- Nurses stations



All ACP, Inc. commercial ovens are backed by our Culinary Center. Call us with any question regarding food preparation, menu development and cooking times. 866-426-2621.

## Low Volume

### MenuMaster Commercial Microwave Model RMS510D

#### Power Output

- 1000 watts of power.
- Full power only for simple operation.

#### Certified Oven for Commercial Applications

- Tested to higher standards for a commercial rating - required by most commercial insurance policies and health inspectors.
- Interlock safety switch is tested to 4 times the standard of residential ovens.
- Constructed to withstand the foodservice environment, multiple users and variable ambient temperatures.
- Compared to a residential oven, this oven is more powerful for faster heating and better quality results.
- Engineered for a simple, "self-service" operation.

#### Easy to Use

- User friendly dial timer designed for self-serve applications.
- 6 minute digital timer lights up for "at-a-glance" monitoring.
- Timer automatically resets to zero if door is open during heating.
- See-through door and lighted interior for monitoring without opening the door.
- 25.5 Liters (0.9 cu. ft.) capacity accommodates a 305 mm (12") platter, prepackaged foods and single servings.

#### Easy to Maintain

- Stainless steel exterior wrap and painted interior for easy cleaning and a commercial look.
- Limited 3 year warranty.
- TUV Listed.



A/A File #:

Specification #:



# Menumaster Commercial Microwave Model RMS510D | Low Volume

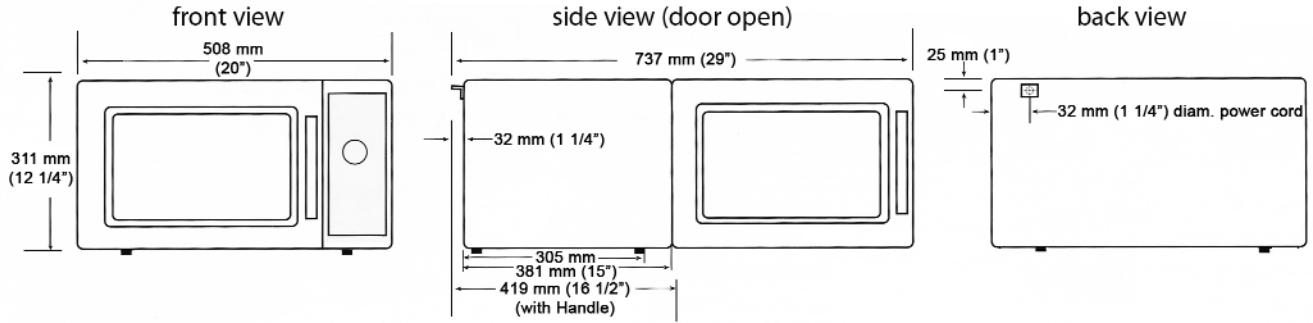

Installation clearance: 3" sides & 12" top

Specification #:

## Specifications

Model	RMS510D	UPC Code	728028020816
Configuration	Countertop		
Control System	Dial		
Max. Cooking Time	6:00		
Power Levels	1		
Time Entry Option	Yes		
Microwave Distribution	Rotating stirrer, bottom		
Magnetron	1		
Stage Cooking	1 stage		
Interior Light	Yes		
Door Handle	Grab & Go		
Signal	End of cycle		
Exterior Dimensions	H 311.15 (12 1/4")	W 508 (20")	D* 419 (16 1/2")
Cavity Dimensions	H 196.85 (7 3/4")	W 330.2 (13")	D 330.2 (13")
Door Depth	749.3 (29 1/2"), 90°+ door open		
Usable Cavity Space	25.5 Liters (0.9 cubic ft.)		
Exterior Finish	Stainless steel wrap		
Interior Finish	Painted		
Power Consumption	1150 W, 9.6 A		
Power Output**	1000 W** Microwave		
Power Source	230V, 50 Hz, 15 A single phase		
Plug Configuration / Cord	CEE 7/7	1.5 m (5 ft.)	
Frequency	2450 MHz		
Product Weight	14.5 kg. (32 lbs.)		
Ship weight (approx.)	17.7 kg. (39 lbs.)		
Shipping Carton Size	H 15" (381)	W 23" (584.19)	D 18" (457.2)

Measurements are in millimeters

\* Includes handle

\*\*IEC 705 Tested

## Specifications

Commercial microwave shall have a user-friendly 6 minute dial timer with illuminated digits and end of cycle audible signal. Timer shall automatically reset to zero if the door is opened during heating. Oven shall have one power level - full power. Microwave output shall be 1000 watts distributed by one magnetron with a bottom feed rotating stirrer to provide superior even heating throughout the cavity. Durable door shall have a tempered glass window and a grab and go handle with a 90°+ opening for easy access. An interior light shall facilitate monitoring without opening the door. The 25.5 Liters (0.9 cubic ft.) cavity shall accommodate a 305 mm (12") platter. Oven shall have a stainless steel exterior wrap and white powder coat painted interior. Microwave oven shall comply with standards set by the U.S Department of Health and Human Services, TUV listed.



## Warranty

Limited 3 year warranty:

Year 1 - parts, labor, and travel are covered.

Years 2 - 3 - magnetron tube (part only) is covered.

AIA File #:

