

Quality Food, Fast.

The Menumaster® MOC5241

In the foodservice business time is money. Make the most of your time by utilizing one of the most powerful commercial ovens you can buy — the Menumaster MOC5241. Dependable and durable, this oven provides fast, even-heating and superior food quality.

Key Features

- ◆ 2400 Watts of power for fast heating.
- ◆ 9 Liters usable cavity space
- ◆ Unique “jigsaw” shaped footprint allows for back-to-back placement on a 724mm shelf.
- ◆ Door automatically opens at end of cook cycle and remains open until next cook cycle begins.
- ◆ Up to 100 programmable menu items simplifies cooking and ensures consistent results.
- ◆ Control panel located on bottom for convenient access and angled for easy viewing.
- ◆ Four Stage Cooking Option for one-touch cooking. Reduces prep time, labor and food waste while providing consistent results.
- ◆ Door extends out for easy cleaning.
- ◆ Plug and play operation
- ◆ Durable stainless steel exterior and interior for years of commercial foodservice use.
- ◆ Worldwide service network provides ongoing product support.
- ◆ Limited 3 year warranty.

MOC5241

2400 Watts

COMMERCIAL MICROWAVE OVEN



A Powerful & Cost-Effective Way to . . .

- ◆ Serve quality food, quickly
- ◆ Increase food sales and profits
- ◆ Cook fresher, hotter foods on demand

Maximize Your Profits

The powerful Menumaster MOC5241 is built to handle the fast pace and grueling demands of the busiest kitchens. It's a high-performing, heavy-duty unit that's ideal for boost-heating. Perfect for use in:

High-Volume Chains

For more information about any of our fine commercial microwave ovens, visit our web site at www.acpsolutions.com.

Form #MCO0952 rev. 7/10

©2009 ACP, Inc.
Printed in the USA.



ACP
INC.
HIGH PERFORMANCE HAS A NAME™
MENUMASTER

MOC5241

2400 Watts

COMMERCIAL MICROWAVE OVEN

SPECIFICATIONS

UPC Code	705105607306
Configuration	Countertop or shelf
Control System	Touch
Programmable Control Pads	10
Total Programmable Settings	100
Cooking Timer	10:00
Power Levels	11
Defrost	Yes
Microwave Distribution System	Rotating Antenna
Magnetron(s)	2
Display	LED
Stackable	Yes
Stage Cooking	4 stages
Door Opening System	Automatic opening
Signal	Door automatically opens at end of cycle
Automatic Voltage Sensor	Yes
Warranty	Limited 3 Year

Cabinet	Exterior Dimensions	Usable Interior Dimensions
Height	451 mm (17-3/4")	136 mm (5-3/8")
Width	346 mm (13-5/8")	298 mm (11-3/4")
Depth (overall with handle)	473 mm (18-5/8")	222 mm (8-3/4")
Usable Cavity Space	9 Liters (.319 cubic ft.)	
Outercase Material	Stainless Steel	
Cavity Interior Finish	Stainless Steel with Sealed-in Ceramic Shelf	

Electrical Characteristics	
Power Consumption	3100W
Power Output	2400 W
Power Source	230 V, 50 Hz, 16 A single phase
Plug Configuration	CEE7/7 "Schuko" 
Frequency	2450 MHz
Power Cord Length	133mm (5-1/4")

Weight/Shipping Information	
Net Weight	32 kg (70 lbs.)
Approximate Shipping	33 kg (73 lbs)
Shipping Box Size	D: 524mm (20-5/8") x W: 432mm (17") x H: 559mm (22")

ACP's continuing commitment to quality products may mean a change in specification without notice.
 Certified to IEC60335-2-90 meeting particular requirement for commercial microwave ovens.

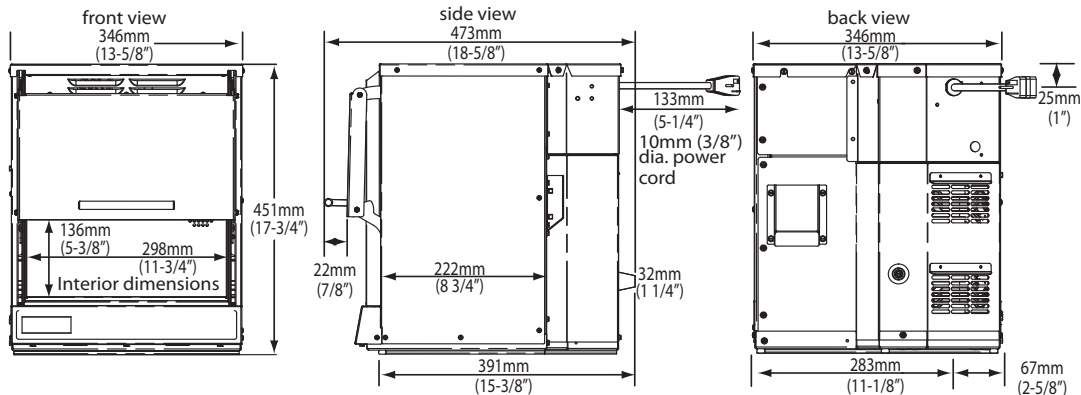

Form #MCO0952 rev. 7/10

For more information about any of our fine commercial microwave ovens, visit our web site at www.acpsolutions.com.

©2009 ACP, Inc.
 Printed in the USA.



ACP
 INC.
 HIGH PERFORMANCE HAS A 'NAME'
MENUMASTER