



Outperform every day.™

Distributor:
KiD Catering Equipment
Oaktree Court Business Centre
Mill Lane, Ness, Cheshire, CH64 8TP
Tel: 0333 123 2450
sales@kidcateringequipment.com

INTERNATIONAL MIRAGE® 16" X 16" INDUCTION BUFFET WARMERS



ITEMS

Item No.	Model No.	Description	Plug
595027502	5950275	Countertop, Black	Schuko
595027503			UK
595027504			China
595027505			Australia
595028002	5950280	Countertop, Natural	Schuko
595028003			UK
595028004			China
595028005			Australia
59502DW02	59502DW	Drop-in	Schuko
59502DW03			UK
59502DW04			China
59502DW05			Australia

FEATURES

- Connect up to three warmers with the included interconnect cords. The center warmer must connect to the electrical outlet.
- Up to seven warmers (at maximum power) can be connected to a 10 amp circuit
- Storage compartment under warmer conveniently holds cords
- Touch controls
- Four power levels
- LED indicator lights on control panel and glass top
- Tempered ceramic glass top is strong, non-porous and easy to clean
- Low profile design focuses on the food and compliments any decor
- Drop-in warmers can be installed overhanging countertop or countersunk
- 6 ft. (183 cm) cord with plug
- 30 in. (76.2 cm) interconnect cord
- 5 ft. (152.4 cm) USB cable for remotely mounted control box for drop-in warmers

DESCRIPTION

Maximize your menu offerings without maxing out your electrical capacity with the Mirage® 16" x 16" Induction Buffet Warmers. The low wattage warmers can be interconnected to one electrical outlet, which simplifies the planning and management of power cords, access to outlets and load capacity. Available in countertop and drop-in styles, these warmers are ideally suited for buffet and catering operations

These induction buffet warmers are designed to work with a maximum of one induction-ready chafer or serving vessel.

The Mirage® 16" x 16" Induction Buffet Warmers are equipped with a variety of safety features including:

- Over-heat protection
- Small-article detection
- Pan auto-detection function
- Empty-pan shut-off

WARRANTY

All models shown come with Vollrath's standard warranty against defects in materials and workmanship. For full warranty details, please refer to www.Vollrath.com.

AGENCY CERTIFICATIONS



Due to continued product improvement, please consult www.vollrath.com for current product specifications.

ACCESSORIES

- 59145 Carrying Case
- 4644080 Non-Slip Mat - 9" x 8" (22.9 x 20.3 cm)
- 4644070 Non-Slip Mat - 16" x 8" (40.6 x 20.3 cm)

IMPORTANT

- This appliance is intended for use with induction-ready serving vessels.
- Countertop models require a distance equal to the height of the feet of the warmer.
- Drop-in models require a minimum of 2" (5 cm) of space between all four sides of the induction warmer and any surrounding surface, and a minimum 12" (30.5 cm) between the bottom of the induction warmer and any surrounding surface.
- Control box for drop-in models requires a minimum of 4" (10 cm) behind the control box and any surrounding surface.
- All models require unrestricted intake and exhaust air ventilation for proper operation of the controls. The maximum intake temperature must not exceed 110°F (43°C). Temperatures are measured in ambient air while all appliances in the kitchen are in operation.

Approvals	Date

INTERNATIONAL MIRAGE® 16" X 16" INDUCTION BUFFET WARMERS

DIMENSIONS (Shown in inches (cm))

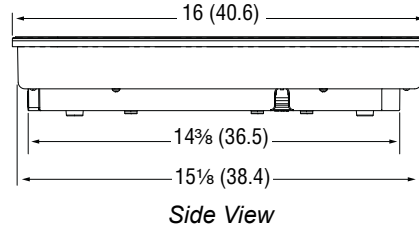
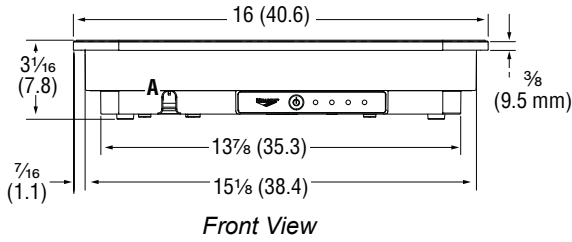

Drop-in Model, Overhung Installation

Drop-in Model, Countersunk Installation

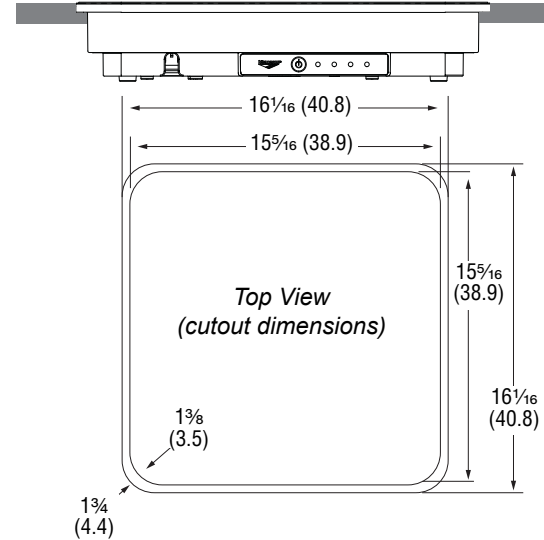
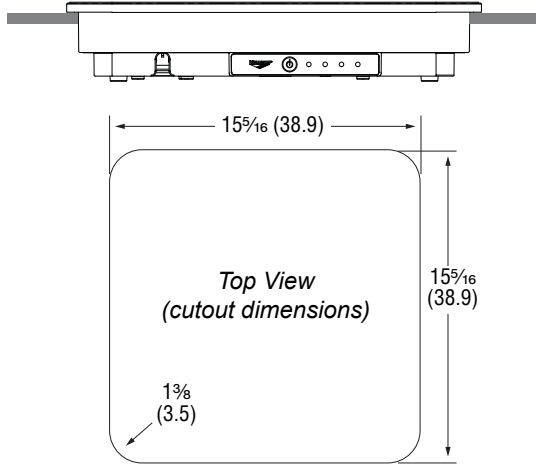

Control Box (drop-in models only)

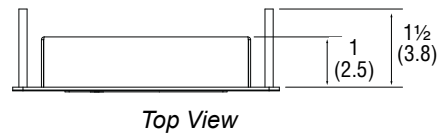
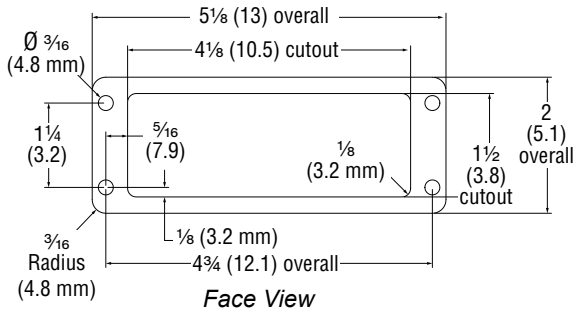

SPECIFICATIONS

Item No.	Description	Max Pan Size	Watts	Volts	Amps	Hz	Plug	Weight LB (KG)						
595027502	Countertop, Black	14 (35.6)	300	230	1.3	50/60	Schuko	14 (6.4)						
595027503							UK							
595027504							China							
595027505	Australia													
595028002	Schuko													
595028003	Countertop, Natural	14 (35.6)	300	230	1.3	50/60	UK	14 (6.4)						
595028004							China							
595028005							Australia							
59502DW02	Drop-in						14 (35.6)		300	230	1.3	50/60	Schuko	14 (6.4)
59502DW03													UK	
59502DW04		China												
59502DW05	Australia													

Receptacles

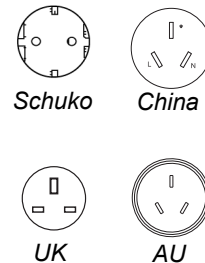

Distributor:
 KiD Catering Equipment
 Oaktree Court Business Centre
 Mill Lane, Ness, Cheshire, CH64 8TP
 Tel: 0333 123 2450
 sales@kidcateringequipment.com