

Victor

Banquetline



Model Number: **BL30H1-R/L**

Prepare & store hot food in advance of desired serving time.

The blown air heating system keeps food in optimum condition until required.

Accepts 2 x GN1/1 containers - 65 mm deep per level or maximum of 30 plated meals

Maintain speedy service in times of peak demand.

Low height unit designed to "roll under" counter if required.

BL30H1-R - Door hinged to right
BL30H1-L - Door hinged to left

Dimensions

External: 675 x 785 x 860mm
Internal: 585 x 665 x 500mm

Electrical Connection

220V/240V, 1 phase, 50 Hz, 1.5kW loading, 6.3 Amps
Cable: 2 metres with 13 amp plug fitted

Capacity

10 x GN1/1 containers - 65mm deep
(Containers not included)

30 x 10" dia. plates with 60mm plate covers max.
(5 plates per level, 6 stacks)

Product Features

- Four x 100mm heavy duty swivel castors two braked.
- Complete with 3 shelves and pair of supports
- All stainless steel construction
- Top mounted digital temperature control adjustable between 65 and 95 degrees centigrade.
- Integral water reservoir to cabinet base
- Front mounted push/pull bar

Extras

Gastronorm containers
Additional shelves and supports
Plate covers



BL30H1-R model - containers not included

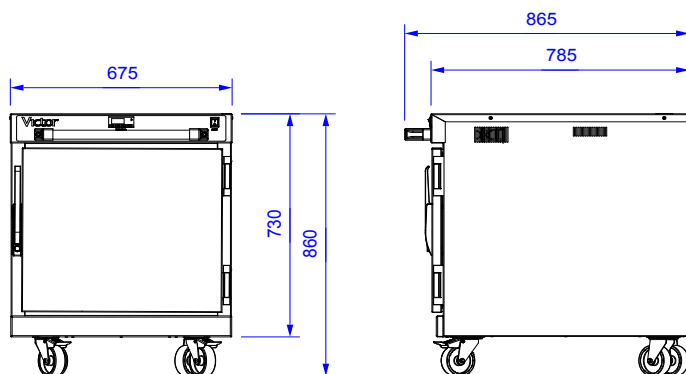

KiD Catering Equipment
Oaktree Court Business Centre
Mill Lane, Ness
Cheshire
CH64 8TP
Tel: 0333 123 2450
sales@kidcateringequipment.com