

CHEFTOP MIND.Maps™



BUTCHER & DELI SHOP

LONGLife4!

Spare parts 4 years / 10.000 hours optional warranty*





VERSATILITY, EASE-OF-USE, RELIABILITY.

The ingredients of your success.

Roasting, braising, grilling, frying, pan-frying, smoking, boiling, steaming, sous-vide cooking.

With the CHEFUNOX mode of CHEFTOP MIND.Maps™, everything is easier: you only have to select the cooking method you want to use. The oven will then ask you to choose the result you aim to achieve and the cooking program will start, enhancing the flavor and aroma, with maximum yield for every batch.

Hyper.Smoker technology allows you to add the unmistakable smell and taste of smoke to your food and make your offering unique.

Why limit yourself?

VERSATILITY.

UNOX Solutions for Butcher & Deli Shop.

10 GN 1/1 + CABINET



XEVC-1011-EPR
 10 GN 1/1
 67 mm
 50 / 60 Hz
 400 V - 3N
 18,5 kW
 750x773x1010
 95 kg

7 GN 1/1 + CABINET



XEVC-0711-EPR
 7 GN 1/1
 67 mm
 50 / 60 Hz
 400 V - 3N
 11,7 kW
 750x773x843
 85 kg

10 GN 2/1 + CABINET



XEVC-1021-EPR
 10 GN 2/1
 77 mm
 50 / 60 Hz
 400 V - 3N
 30,8 kW
 860x1120x1163
 170 kg

10 600x400 + CABINET



XEBC-10EU-EPR
 10 600x400
 80 mm
 50 / 60 Hz
 400 V - 3N
 21 kW
 860x957x1163
 130 kg

5 + 5 GN 1/1 + STAND



XEVC-0511-EPR
 5 GN 1/1
 67 mm
 50 / 60 Hz
 400 V - 3N
 9,3 kW
 750x773x675
 70 kg

Capacity
 Pitch
 Frequency
 Voltage
 Electrical power
 Dimensions (WxDxH mm)
 Weight

Stacking kit*

Capacity
 Pitch
 Frequency
 Voltage
 Electrical power
 Dimensions (WxDxH mm)
 Weight

Pollo kit

XWVEC-0811
 8 GN 1/1
 57 mm
 -
 -
 -
 750x656x676
 18 kg

XWVEC-0811
 8 GN 1/1
 57 mm
 -
 -
 -
 750x656x676
 18 kg

XWVEC-0821
 8 GN 2/1
 57 mm
 -
 -
 -
 860x995x676
 30 kg

XWAEC-08EF
 8 600x400
 57 mm
 -
 -
 -
 860x772x676
 25 kg

XWVRC-0011-M
 -
 -
 -
 -
 -
 732x546x462
 9 kg

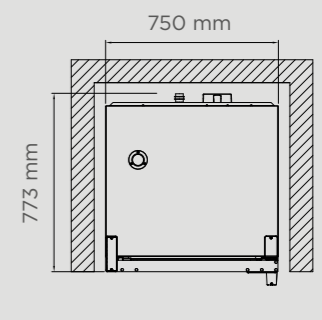
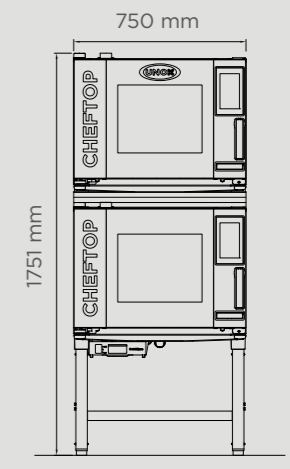
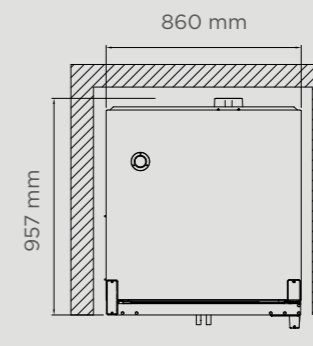
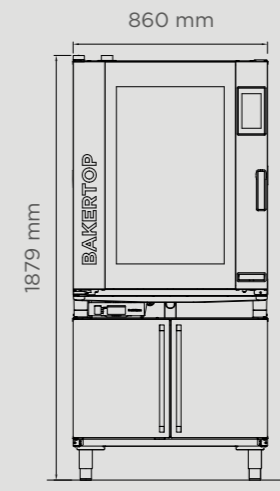
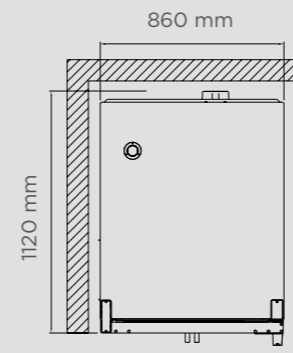
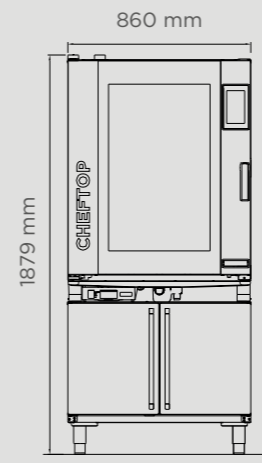
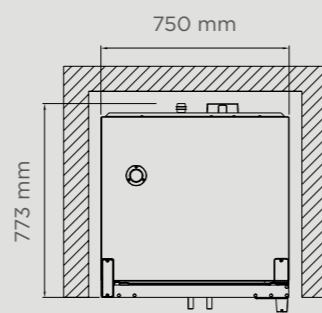
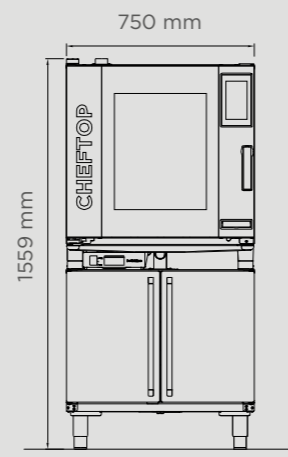
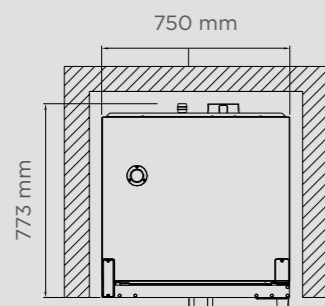
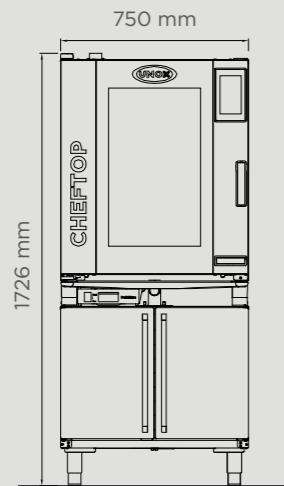

* Mandatory

POLLO SYSTEM.

Maximizing the value of your investment.

Compared to a traditional roaster, the CHEFTOP MIND.Maps™ *Pollo*-System significantly reduces cooking time and weight loss, assuring perfect results with any amount of food loaded. The special *Pollo*-grill enables you to exploit the cooking chamber space and optimize the air flow inside and outside every chicken.

The semi-automatic system of drain-liquid separation makes fat collection and disposal an easy task.

Pollo-Wash, the tray-washing basket, enables you to wash the *Pollo*-grills in the oven during its normal wash cycle, allowing you more time to focus on your business and your customers.

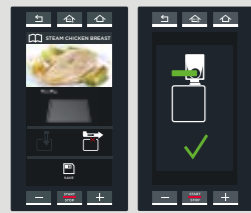

DRAIN SYSTEM
WITHOUT FAT
COLLECTION

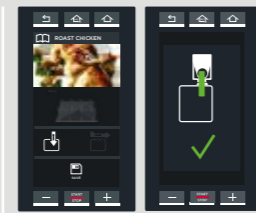

DRAIN SYSTEM
WITH FAT
COLLECTION

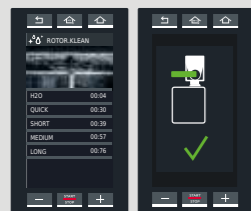
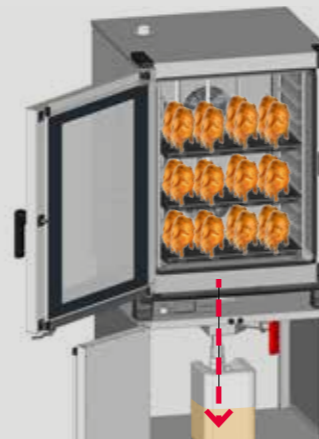

WASHING SYSTEM
Pollo-GRIDS



Pollo-Wash
Washing basket for *Pollo*-trays
Enables you to wash three *Pollo*-grills in
the oven during its normal wash cycle.

Art: GRP860



Pollo-System
Link to video

Pollo Accessories

Pollo-manual kit for neutral cabinet and high open stand
For models: XWVEC-0821/
XWVRC-0021-H/
XWVEC-0811/ XWVRC-0011-H/
XWAE-08EF/
XWARC-00EF-H
Art: XUC020

Pollo-
No stick stainless steel grid to grill 8 chickens
For GN 2/1 & GN 1/1 ovens
Art: GRP 825

Pollo-Wash
Washing basket for pollo trays
For GN 2/1 & GN 1/1 ovens
Art: GRP 860

GN 2/1 Equipments

Neutral cabinet
Art: XWVEC-0821

High open stand
Art: XWVRC-0021-H

Basket
Capacity: 10 GN 2/1
6 x GRP 825 = 48 chickens
Art: XWVBC-1021

Basket
Capacity: 6 GN 2/1
4 x GRP 825 = 32 chickens
Art: XWVBC-0621

Trolley for basket
For XWVBC-1021/
XWVBC-0621
Art: XWVYC-0021
Trolley coupling kit
Required article
with the purchase of
XWVYC-0021.
Art: XWVYC-CK21

GN 1/1 Equipments

Neutral cabinet
Art: XWVEC-0811

High open stand
Art: XWVRC-0011-H

Basket
Capacity: 9 GN 1/1
3 x GRP 825 = 24 chickens
Art: XWVBC-0911

Basket
Capacity: 6 GN 1/1
2 x GRP 825 = 16 chickens
Art: XWVBC-0611

Trolley for basket
For XWVBC-0911/
XWVBC-0611
Art: XWVYC-0011
Trolley coupling kit
Required article with the
purchase of XWVYC-0011.
Art: XWVYC-CK11

600x400 Equipments

Neutral cabinet
Art: XWAE-08EF

High open stand
Art: XWARC-00EF-H