

EVOX FT 12/24 TRAYS 80 Kg

Standard features:

Plug-in with air condensation, R452A unit

Hinges on the right, non-reversible door

Drain on the bottom, standard drip tray included

Trays support structure 12 levels (included in the price)

RATIONAL compatible

Blast Chilling

80 kg

 +90°C → +3°C
90 min

Deep Freezing

50 kg

 +90°C → -18°C
240 min

Capacity

1 STRUCTURE
12 GN2/1 | EN60x80
CONSUMPTION (prEN 17032)

Blast Chilling	Deep Freezing
+90°C / +3°C	+90°C / -18°C
0,10 kWh/kg	0,34 kWh/kg

REFRIGERANT GAS

Type	GWP	Charge
R452A	2141	2,2 kg
R448A**	1387	0,0 kg
R449A**	1397	0,0 kg

** on request without refrigeration unit

ROOM CONDITIONS

+32°C

60% UR

CERTIFICATION

TECHNICAL DATA

Code	FTW12.80	FTW12.80W	FTW12.80SG
Version	Air	Water	Without group
Dimensions (L x P x H)	1030 x 1045 x 1810/1850 mm	1030 x 1045 x 1810/1850 mm	1030 x 1045 x 1810/1850 mm
Net Weight	275 kg	275 kg	185 kg
Insulation Thickness	70 mm	70 mm	70 mm
Standard Tension	400 V / 3 Ph+N / 50 Hz	400 V / 3 Ph+N / 50 Hz	400 V / 3 Ph+N / 50 Hz
Power Consumption	4,5 kW / 14,0 A	4,5 kW / 14,0 A	1,0 kW / 4,0 A
Refrigeration power (*Te= -10°C)	9.700 W	9.700 W	/
Refrigeration power (*Te= -30°C)	3.560 W	3.560 W	/
Noise	<70 dB	<70 dB	<70 dB
HP	5,5 HP	5,5 HP	/

*Te = Expansion temperature - Condensation temperature = +45°C

SPECIFICATIONS IN COMPLIANCE WITH prEN 17032







Blast Chilling (+65°C / +10°C)		Deep Freezing (+65°C / -18°C)	
Maximum capacity	Time	Maximum capacity	Time
80 kg	120 min	50 kg	260 min

Distributor:

 KiD Catering Equipment, Oaktree Court Business Centre, Mill Lane, Ness, Cheshire, CH64 8TP
 Tel: 0333 123 2450

sales@kidcateringequipment.com

CONTROLLER

 BLAST CHILLING	 DEEP FREEZING	 USB	 FAN SPEED REGULATION	 RECIPE BOOK	 COLD HOLDING (TOP) & HOT (PLUS)	 THAWING -18°C ⇌ +3°C	 LEAVENING (PLUS)	 SLOW COOKING (PLUS)
---	--	--	---	--	--	---	---	--

TOP - STANDARD

- Automatic cycles and RECIPE BOOK with pre-set programs;
- Blast Chilling + 3°C HARD/SOFT with core probe/time duration + automatic conservation;
- Deep Freezing -18°C HARD/SOFT with core probe/ time duration + automatic holding;
- Fan-speed regulation;
- Cold conservation function;
- Favourites function: quick access to most used programs;
- Special cycle for the raw fish sanitation;
- Non-stop cycle for the ice cream hardening;
- Controlled thawing from -20°C to +3°C;
- Chamber drying to remove humidity.











PLUS - OPTIONAL

- TOP Functions;
- Controlled leavening with customizable phases;
- slow cooking +65°C with humidity and ventilation control;
- Hot conservation function;
- Combined cycle for sequentially execution of different cycles.

CONSTRUCTIVE FEATURES

Stainless steel structure AISI 304 18/10, external Scotch-Brite, internal mirror finish; rounded inner and outer angles for a perfect and easy cleaning; space under the evaporator for a perfect cleaning; oversized condenser to ensure reliability; Italian high-performance refrigerating units; special fans suitable for low temperatures with speed regulation system; evaporators with cataphoresis anticorrosion treatment; the technical room of evaporator and condenser can be easily inspected.

ACCESSORIES

	Leavening cycles and Slow Cooking ACC FT12		LED Light ACC 148
	Kit 4 Castors ACC 141		Left Opening Door ACC 136
	Ozone sterilizer ACC 110		Heated Core Probe ACC 509
	Trays support structure 12 GN2/1 ACC 165		Multipoint core probe ACC 510
	Trays support structure 12 EN60x80 ACC 168		Trolley ACC 171

Distributor:

 KiD Catering Equipment, Oaktree Court Business Centre, Mill Lane, Ness, Cheshire, CH64 8TP
 Tel: 0333 123 2450 sales@kidcateringequipment.com

DIMENSIONS

Front View

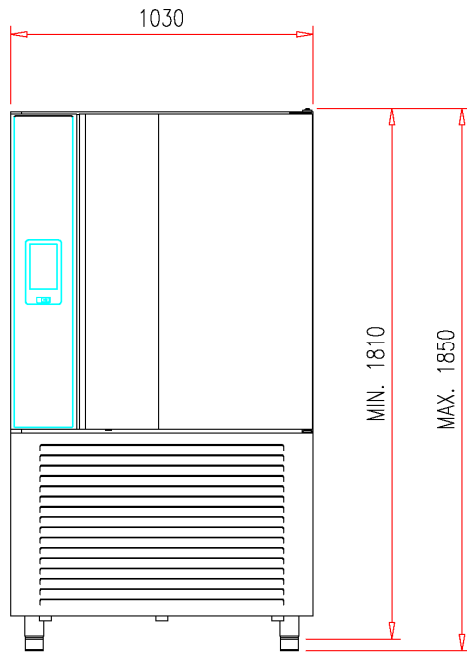

Side View

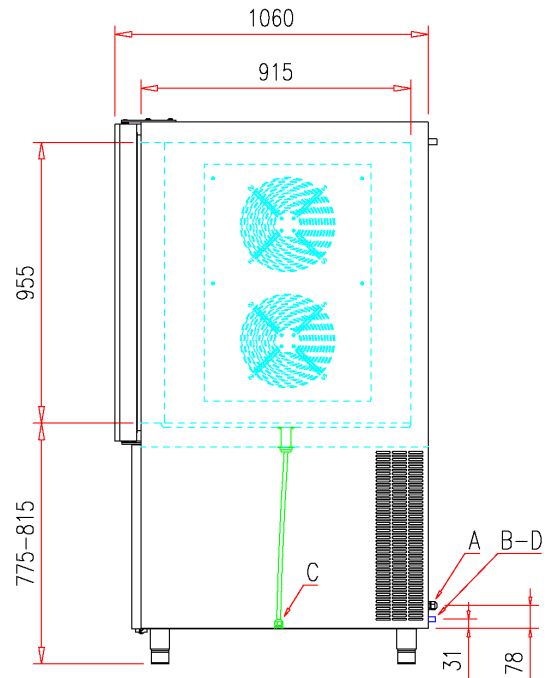

Top View

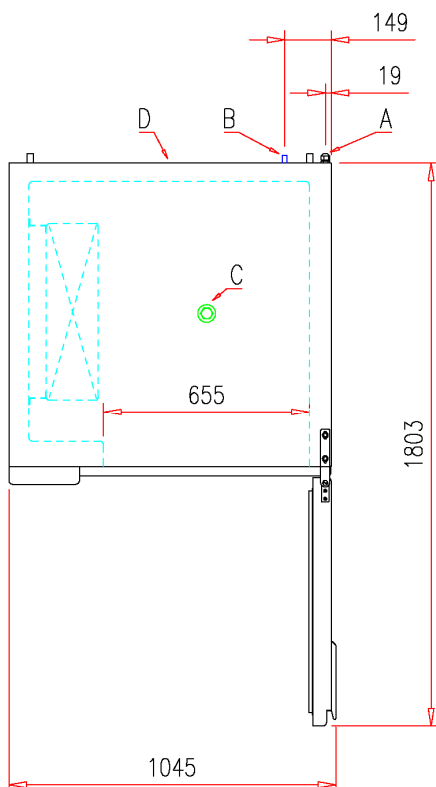

CONNECTIONS

- A = Electrical connection
- B = Water connection (if required)
- C = Evaporator water drain pipe
- D = Refrigeration Connection (if required)

Distributor:

KiD Catering Equipment, Oaktree Court Business Centre, Mill Lane, Ness, Cheshire, CH64 8TP
Tel: 0333 123 2450

sales@kidcateringequipment.com