

ACTIVA 10 TRAYS COMPACT

Standard features:

Plug-in with air condensation, R452A unit

Hinges on the right, non-reversible door

Drain on the bottom, standard drip tray included

Bivalent trays support GN 1/1 and EN 60x40

Blast Chilling

35 kg

 +90°C → +3°C
 90 min

Deep Freezing

18 kg

 +90°C → -18°C
 240 min

Capacity

**10 GN 1/1
 (10 EN60x40)**
CONSUMPTION (prEN 17032)

Blast Chilling	Deep Freezing
+90°C / +3°C	+90°C / -18°C
0,10 kWh/kg	0,32 kWh/kg

REFRIGERANT GAS

Type	GWP	Charge
R452A	2141	1,1 kg

ROOM CONDITIONS

+32°C

60% UR

CERTIFICATION

TECHNICAL DATA

Code	MXT10.35
Version	Air
Dimensions (L x P x H)	798 x 808 x 1480/1520 mm
Net Weight	150 kg
Insulation Thickness	70 mm
Standard Tension	230 V / 1 Ph / 50 Hz
Power Consumption	1,6 kW / 9,0 A
Refrigeration power (*Te= -10 °C)	3.200 W
Refrigeration power (*Te= -30 °C)	1.150 W
Noise	<70 dB
HP	1,2 HP

*Expansion temperature - Condensation temperature

SPECIFICATIONS IN COMPLIANCE WITH prEN 17032

Blast Chilling (+65°C / +10°C)		Deep Freezing (+65°C / -18°C)	
Maximum capacity	Time	Maximum capacity	Time
35 kg	120 min	18 kg	260 min

Distributor:

 KiD Catering Equipment, Oaktree Court Business Centre, Mill Lane, Ness, Cheshire, CH64 8TP
 Tel: 0333 123 2450 sales@kidcateringequipment.com

CONTROLLER

 BLAST CHILLING	 DEEP FREEZING	 STANDARD CORE PROBE	 AUTOMATIC CONSERVATION	 RAW FISH SANITATION	 HACCP ALARMS	 HEATED CORE PROBE (OPTIONAL)	 STERILIZER (OPTIONAL)
---	--	--	---	--	---	---	--

Available cycles:

- Temperature-blast chilling with core probe + conservation phase;
- Time-blast chilling time without core probe + conservation phase;
- Temperature-deep freezing with core probe + conservation phase;
- Time-deep freezing without core probe + conservation phase;
- SOFT and HARD cycles for both blast chilling +3°C or deep freezing -18°C;
- Pre-cooling cycle.





Special functions:

- Automatic control on core probe insertion;
- Core probe temperature visualization;
- Visualization of elapsed time from start, customizable by user;
- Raw fish sanitation cycle;
- Manual defrost.

CONSTRUCTIVE FEATURES

Stainless steel structure AISI 304 18/10, external Scotch-Brite, internal mirror finish; rounded inner and outer angles for a perfect and easy cleaning; space under the evaporator for a perfect cleaning; oversized condenser to ensure reliability; Italian high-performance refrigerating units; special fans suitable for low temperatures; evaporators with cataphoresis anticorrosion treatment; the technical room of evaporator and condenser can be easily inspected.

ACCESSORIES

	Kit 4 Castors ACC 140		Left Opening Door ACC 135
	Ozone sterilizer ACC 110		Heated Core Probe ACC 509

Distributor:

DIMENSIONS

Front View

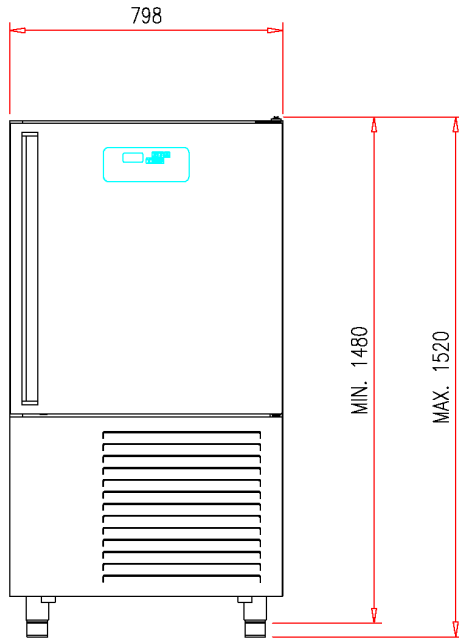

Side View

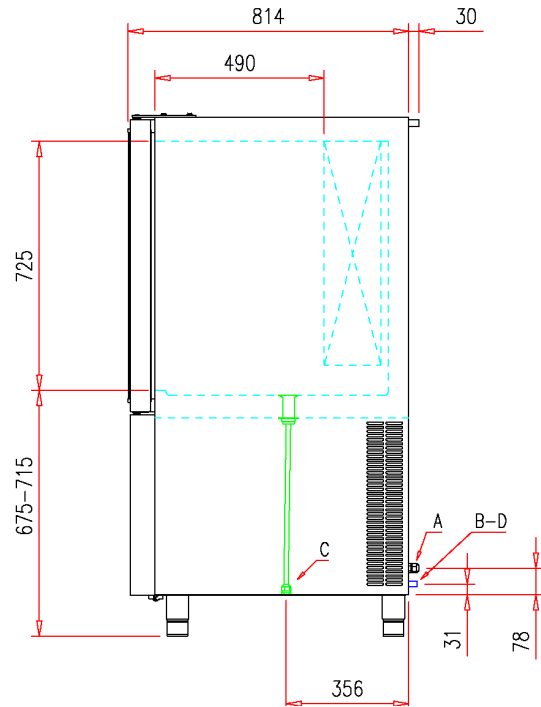

Top View

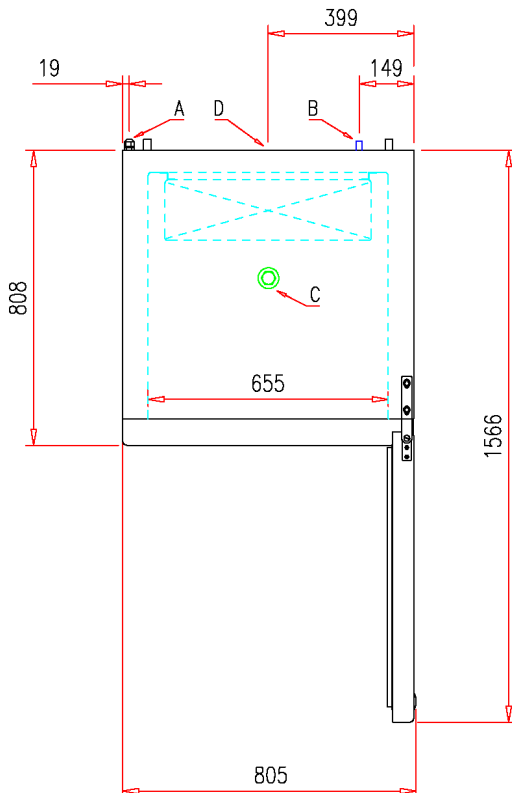

CONNECTIONS

- Electrical connection
- Water connection (if required)
- Evaporator water drain pipe
- Refrigeration Connection (if required)

Distributor:

KiD Catering Equipment, Oaktree Court Business Centre, Mill Lane, Ness, Cheshire, CH64 8TP
Tel: 0333 123 2450 sales@kidcateringequipment.com