



POTATO PEELER PPC-6+ 230/50/1 .550W

Output: 6 Kg. per cycle. Aluminium made potato peeler.

1000431



FEATURES AND BENEFITS

- ✓ Aluminium body potato peeler. Abrasive peeling. The abrasive is highly resistant and long lasting.
- ✓ Base Plate and chamber walls lined with abrasive.
- ✓ Aluminium body.
- ✓ PPC: Equipped with attachment drive to power accessories.
- ✓ Directable cylinder.
- ✓ Integral control panel complete with on/off push buttons and a 0-6 minute timer.

SALES DESCRIPTION

PPC: Equipped with attachment drive to power accessories.

INCLUDES

- ✓ Attachment drive to power accessories (PPC model).

ACCESSORIES

- Vegetable preparation attachment CR-143
- Meat mincer attachment HM-71
- Potato masher attachment P-132
- Stands for potato peelers
- Filters for potato peelers



Distributor:
 KiD Catering Equipment
 Oaktree Court Business Centre
 Mill Lane, Ness, Cheshire, CH64 8TP
 Tel: 0333 123 2450
 sales@kidcateringequipment.com

Project

Date

Item

Qty

Approved

DYNAMIC PREPARATION
COMMERCIAL POTATO PEELERS

product sheet
updated 30/06/2020



POTATO PEELER PPC-6+ 230/50/1 .550W

Output: 6 Kg. per cycle. Aluminium made potato peeler.

1000431

SPECIFICATIONS

- Hourly production: 120 Kg / 150 Kg
- Capacity per load: 6 Kg
- Timer (min-max): 0 ' - 6 '
- Total loading: 550 W
- Plate speed: 317 rpm
- Electrical supply: 230 V / 50 Hz / 1 ~ (3.5 A)
- Plug: -

External dimensions (WxDxH)

- ✓ Width: 395 mm
- ✓ Depth: 700 mm
- ✓ Height: 433 mm

External dimensions with stand

- ✓ Width with stand: 411 mm
- ✓ Depth with stand: 700 mm
- ✓ Height with stand: 945 mm

Net weight: 37 Kg

Crated dimensions

440 x 710 x 545 mm
Gross weight: 33.5 Kg.

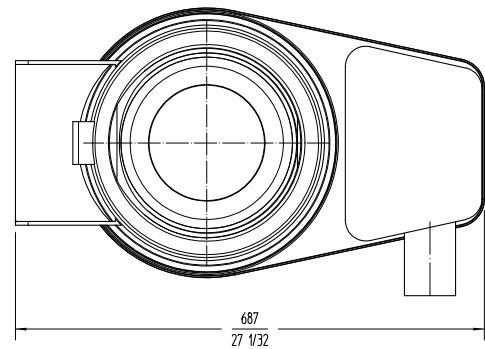
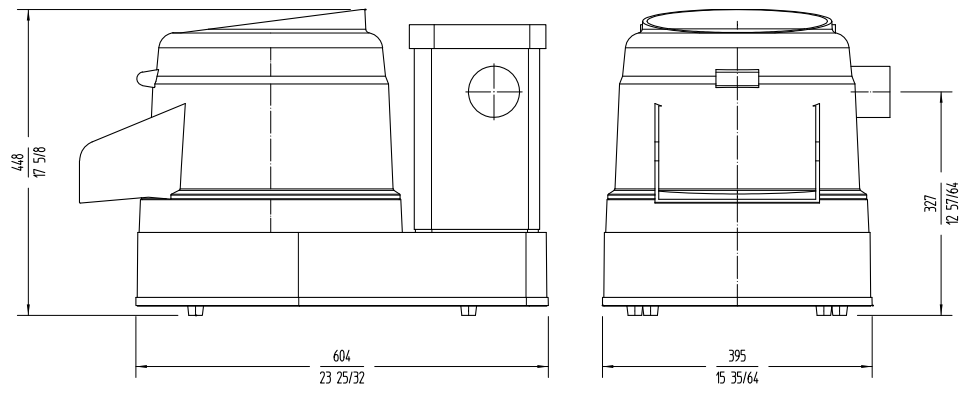

DYNAMIC PREPARATION
COMMERCIAL POTATO PEELERS

Distributor: KiD Catering Equipment Oaktree Court Business Centre Mill Lane, Ness, Cheshire, CH64 8TP Tel: 0333 123 2450 sales@kidcateringequipment.com	Project	Date
	Item	Qty
	Approved	