

D Range

undercounter

DISHWASHER



D512

Maidaid D512 Features

- **2 year warranty**
- Four button bright LED display with soft touch controls, twin traffic lights giving instant status updates & operational self-diagnostics



- Alarms menu with hi-level information retrieval
- Quick release parallel wash & rinse arm design
- Triple wash tank filtration system
- Breaktank as standard
- Drain pump as standard
- Three standard cycle time options with a range of special cycles
- Cycle times can be tailored to site requirements
- Comprehensive automatic self-cleaning at end of service
- Selectable energy saving mode
- Selectable thermostop ensures optimum rinse temperatures
- Fully double skinned minimising both acoustic output and reduced heat loss
- Patented dual flow wash pump with soft start – reducing power consumption whilst retaining wash efficiency
- Full door seal and door ajar facility
- Moulded wash tank for easy cleaning
- Moulded rack guide
- Accurate detergent & rinse aid peristaltic dosing pumps as standard
- Surface scrap tray filter supplied as standard



Supplied with one pegged (capable of holding 18 10" plates), one open rack (capable of holding 25 pint glasses) and cutlery insert.

Additional racks can be purchased



Distributor:

KiD Catering Equipment, Oaktree Court Business Centre, Mill Lane, Ness, Cheshire, CH64 8TP
Tel: 0333 123 2450 sales@kidcateringequipment.com

D Range

undercounter

DISHWASHER

D512



Technical Data

Dimensions (W x D x H)	mm	600 x 600 x 810	Wash tank element	kW	2.1
		+ Feet	Boiler element	kW	6
Feet height	mm	10-20	Wash pump	kW	0.47
Rack size	mm	500 x 500	Tank capacity	L	15
Maximum useable height	mm	365	Noise emission	dB(A)	≤ 55
Door opening	mm	390	Packaging Specs		
Theoretical productivity	Racks/h	40	Gross weight	Kg	64
Effective productivity	Racks/h	30*	Cubic volume	m ³	0.45
			Dim. (W x D x H)	mm	670 x 690 x 980

*Allowing 30 seconds for reloading
Cycle times may vary depending on local conditions/services

Installation Diagram – All services must be within 1 meter

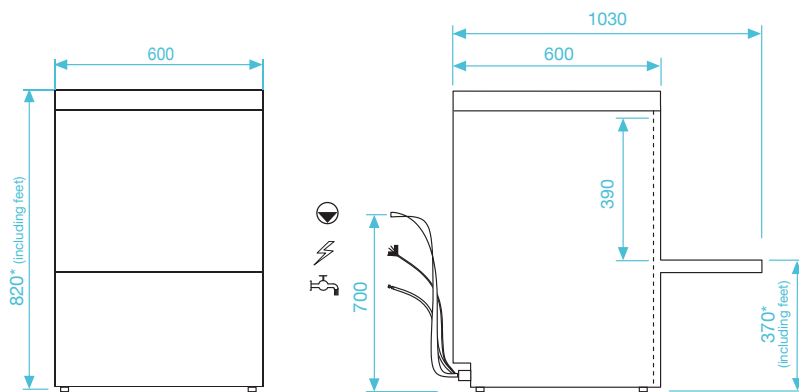

*Height-adjustable feet + 10mm

Power Supply

Installed power	AMP	kW
230V – 50Hz – 1N	13	2.6
	20	4.5
	30*	6.5
Optional 3 Phase config	Total load 6.5kW	
Fused	16 amp	

*Standard configuration

Pumped waste into upstand, maximum height 700mm

Power
 Water supply 2 – 4 bar

Water Connection

Inlet water pressure	Bar	2 to 4
Flow rate L/Min	L/Min	6
Water inlet temp	°C	10 to 50
Water connection	BSP	¾"
Waste connection	Ø	Int 19/ext 24

Cycle Information

Number of standard cycles		3
Standard cycles times	Sec	90/120/150 – adjustable
Special cycle		Eco, Glass, Long, Refresh
Self-cleaning cycle		Yes
Water consumption per cycle	L	2
Wash temperature	°C	60 – adjustable
Rinse temperature	°C	82 – adjustable

Distributor:

KiD Catering Equipment, Oaktree Court Business Centre, Mill Lane, Ness, Cheshire, CH64 8TP
Tel: 0333 123 2450
sales@kidcateringequipment.com