

C Range undercounter DISHWASHER



C512

Maidaid C512 Features

- 2 year warranty
- Four button bright LED line display with soft touch controls, twin traffic lights giving instant status updates & operational self-diagnostics



- Alarms menu with hi-level information retrieval
- Quick release parallel wash & rinse arm design
- Breaktank as standard
- Three standard cycle time options with further options available
- Cycles times can be tailored to site requirements
- Automatic self-cleaning at end of service
- Selectable energy saving mode
- Selectable thermostop ensures optimum rinse temperatures
- Patented dual flow wash pump – reducing power consumption whilst retaining wash efficiency
- Moulded wash tank for easy cleaning
- Moulded rack guide giving partial double skin
- Surface scrap tray filters supplied as standard
- Accurate detergent & rinse aid peristaltic dosing pump as standard

Drain pump version available: C512D

(drain pump cannot be retro fitted)



Supplied with one pegged (capable of holding 18 10" plates), one open rack (capable of holding 25 pint glasses) and cutlery insert.

Additional racks can be purchased



Distributor:

KiD Catering Equipment, Oaktree Court Business Centre, Mill Lane, Ness, Cheshire, CH64 8TP
Tel: 0333 123 2450

sales@kidcateringequipment.com

C Range undercounter DISHWASHER

C512



Technical Data

Dimensions (W x D x H)	mm	580 x 610 x 810 + Feet
Feet height	mm	10-20
Rack size	mm	500 x 500
Maximum useable height	mm	340
Door opening	mm	365
Theoretical productivity	Racks/h	51
Effective productivity	Racks/h	36*

Wash tank element	kW	2.1
Boiler element	kW	6
Wash pump	kW	0.47
Tank capacity	L	20
Noise emission	dB	≤ 55

Packaging Specs

Gross weight	Kg	66
Cubic volume	m ³	0.45
Dim. (W x D x H)	mm	670 x 690 x 980

*Allowing 30 seconds for reloading
Cycle times may vary depending on local conditions/services

Installation Diagram – All services must be within 1 meter

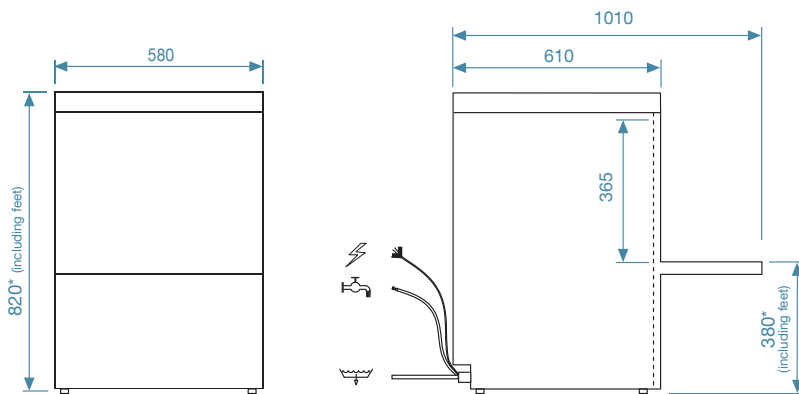

*Height-adjustable feet + 10mm

Power Supply

Installed power	AMP	kW
230V – 50Hz – 1N	13	2.6
	20	4.5
	30*	6.5
Optional 3 Phase config	Total load 6.5kW	
Fused	16 amp	

*Standard configuration

- Power**
- Water supply 2 – 4 bar**
- Gravity drain**

Water Connection

Inlet water pressure	Bar	2 to 4
Flow rate L/Min	L/Min	6
Water inlet temp	°C	10 to 50
Water connection	BSP	¾"
Waste connection	Ø	Int 29/ext 34

Cycle Information

Number of standard cycles	3	
Standard cycles times	Sec	70/90/180 – adjustable
Special cycle	Eco, Glass, Long	
Self-cleaning cycle	Yes	
Water consumption per cycle	L	2
Wash temperature	°C	60 – adjustable
Rinse temperature	°C	82 – adjustable

Distributor:

KiD Catering Equipment, Oaktree Court Business Centre, Mill Lane, Ness, Cheshire, CH64 8TP
Tel: 0333 123 2450 sales@kidcateringequipment.com