

Overview

E&R Moffat Ltd were the originators of a Bainmarie that could be either wet or dry heat. This type of system was designed to offer flexibility and was developed to eliminate the need to fit a low water level warning system or the expense of replacing burned out elements. Wet heat water level is an economic 20 mm deep, complete with drain valve and swing out run off tube for easy emptying /cleaning. A heavy-duty range available in four lengths designed to accommodate 1/1 Gn pans. Excellent for pre-heating plates and dishes, as well as the temporary storage of pre-cooked food. These units incorporate a very efficient heating system, in addition to the fully enclosed heating elements fitted under the Bainmarie well, excess residual hot air from the hot cupboard is also used to maintain temperature.

Use individual or as a part of a specialised Moffat servery counter.



Key Features:

- Insulated for increased efficiency.
- With hygiene in mind all stainless-steel construction, inner panels are bright polished.
- Forced-air, convection, heated cupboard offers unparalleled flexibility of use.
- Fan unit is easily removable for cleaning and maintenance.
- Base and door track in one piece for easy cleaning.
- Thermostatically controlled fan assisted hot cupboard. 30°-110°C.
- Thermostatically controlled bainmarie well 30°-110°C.
- Bainmarie apertures designed for gastronorm pans with raised lip all round for easy pan removal.
- Doors are very easily removed for cleaning, sliding doors have unique double life skid pads.
- Doors can be fully rotated and reinserted allowing the spare skid pads to be used offering a long and trouble-free service.
- Easy lift out GN 1/1 size multiple grid shelving is held by heavy-duty stainless-steel tube supports.
- The recessed, slide-out control panel is mounted to operators right hand side of cupboard.
- Mobile as standard, fitted with 125mm diameter castors all swivel two with brakes.
- Mobility allows for easy kitchen deep clean.
- Fully welded and sealed bainmarie well with drain valve and swing out drain spout
- Complete with a 2-meter-long cable and plug [most units work from a 13-amp supply

Options:

- Doors both sides Add DBS to Code
- Non-mobile on adjustable for height feet [no extra cost but must be stated on order]
- Water inlet Tap for Bainmarie fitted to worktop and piped through to under the base.
- Overhead gantry traditional pass through type. (See Moffat Kitchen pass range)
- Door Locks
- Gastronorm pans



Use wet or dry, with double life door skids, sahara fan heating cell, and a residual supplementary heat system.

Distributor:

KiD Catering Equipment, Oaktree Court Business Centre, Mill Lane, Ness, Cheshire, CH64 8TP
Tel: 0333 123 2450

sales@kidcateringequipment.com



Model	Weight (kg)	L x D x H (mm)	Height to worktop	Power Rating/ Electrical supply	Power Rating with a gantry
HB2	65	947 x 700 x 910	900mm	2.4kw / 13amp	2.62kw / 13amp
HB3	81	1275 x 700 x 910	900mm	2.9kw / 13amp	3.34kw / 16amp
HB4	100	1603 x 700 x 910	900mm	2.9kw / 13amp	3.56kw / 16amp
HB5	118	1931 x 700 x 910	900mm	3.7kw / 32amp	4.58kw / 32amp

Hot cupboard capacity:



Model	10" plated meals Stacked using plate covers	10" plates stacked for heating	Usable internal length & depth	Usable shelf height top / bottom	GN pans side by side 150mm deep
HB2	25 covers / meals	95	695mm / 559mm	195mm / 210mm	4
HB3	35 covers / meals	133	1023mm / 559mm	195mm / 210mm	6
HB4	50 covers / meals	190	1351mm / 559mm	195mm / 210mm	8
HB5	60 covers / meals	228	1679mm / 559mm	195mm / 210mm	10

Note: 10" indicates 10 inch / 255mm diameter plates

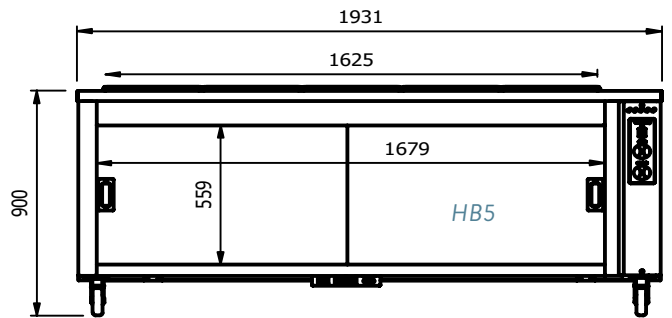
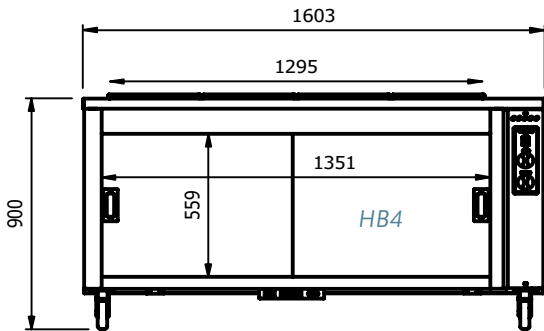
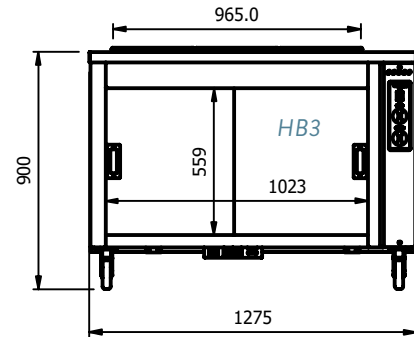
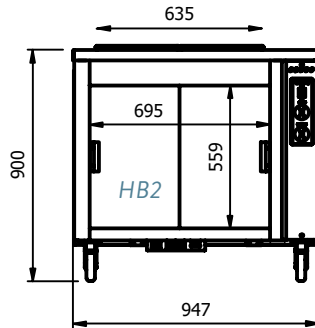
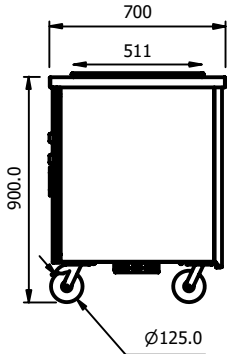

Distributor:
 KID Catering Equipment
 Oaktree Court Business Centre
 Mill Lane, Ness,
 Cheshire
 CH64 8TP
 Tel: 0333 123 2450
 sales@kidcateringequipment.com

