

# ECLIPSE HT3C10

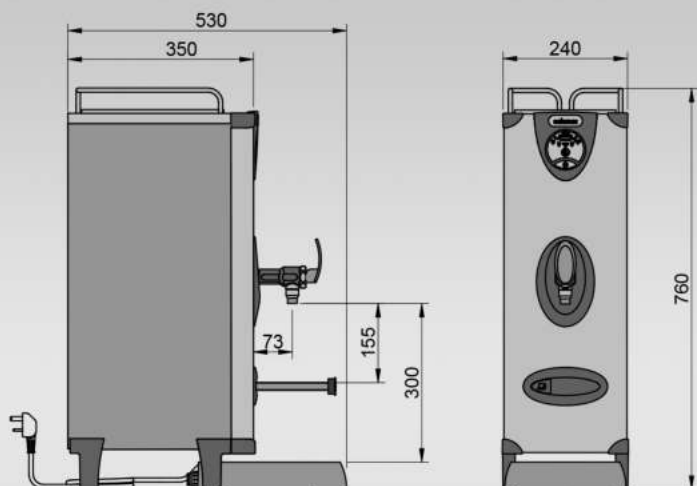

## Key Features:

- UK designed and made
- 10L rapid draw off
- Easy install and service features - removable front panel
- Energy-saving "eco" button which reduces the volume of boiling water by 50% at "off peak" times of demand
- SteriTouch Antimicrobial protection in the tap handle and spill tray
- Clear and unambiguous self-diagnostic display panel
- Integral scale-inhibitor technology
- Extended 2-year warranty
- No steam emissions
- 13A plug fitted
- Discrete on/off switch incorporated into moulding
- Competitively priced
- Cool-to-touch stainless steel outer casing
- Integrated pop-out cup tray and cup rail
- Complete with matching spill-tray
- Supplied complete with food grade hose
- Counter-top securing clamps available as an optional extra



### Distributor:

KiD Catering Equipment, Oaktree Court Business Centre, Mill Lane, Ness, Cheshire, CH64 8TP

Tel: 0333 123 2450 sales@kidcateringequipment.com

SIZE	REF	CASING	RATING	CAPACITY (including initial draw-off)	DIMENSIONS (W x D x H)
10 LITRE	HT3C10	STAINLESS STEEL	3kW	30 LITRES PER HOUR	240 x 530 x 760 (including drip tray)