

CF2

400mm Single Pan Gas Fryer



CF2

- 400mm wide single pan fryer
- 18 litre oil capacity
- 22.5kW multi-jet target burner
- 25kg / hr production rate
- Stainless steel open pan (no tubes)
- 30mm drain valve
- Mechanical thermostat
- Manual pilot ignition
- Baskets and lid included
- Adjustable front feet and rear rollers
- Stainless steel finish

OVERALL CONSTRUCTION

- Stainless steel open tank with cool zone
- Stainless steel exterior front and sides
- Vitreous enamelled front panel
- Double skin door with stainless steel outer
- 63mm dia. stainless steel adjustable legs to front and two rollers at rear
- Two nickel plated wire baskets
- Stainless steel lid supplied standard

CONTROLS

- 100-190°C mechanical thermostat
- Over-temperature safety cut-out
- Manual ignition pilot burner with flame failure

CLEANING AND SERVICING

- Open stainless steel pan for easy clean
- Easy clean stainless steel exterior
- 30mm drain valve for effective draining
- Lift off basket hanger
- Access to all parts from front of unit

Matching Products



CR9D



CR6C



CP4



CT9



C6D



C450



CT6



CS9 / C900-S



C6B



C300

CF2

400mm Single Pan Gas Fryer

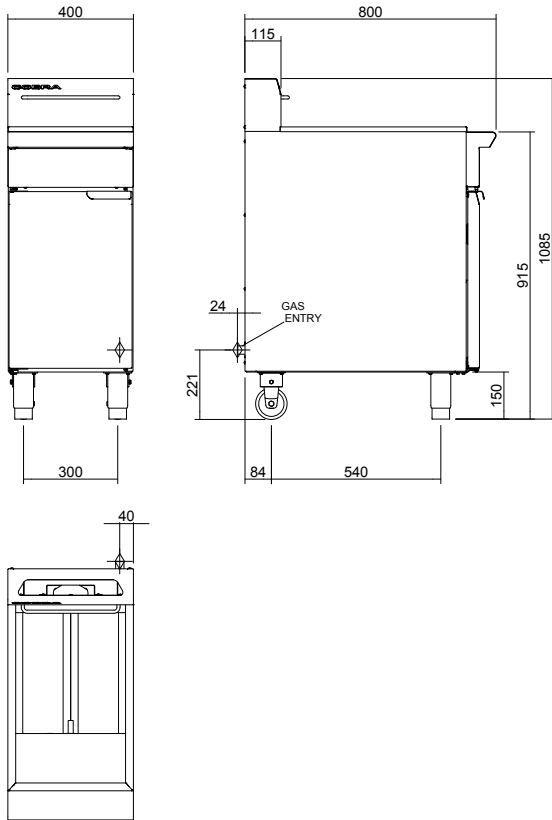

CF2

SPECIFICATIONS

Burners

22.5kW multi-jet target burner

Gas power

Natural gas
22.5kW (nett), 85,250 Btu/hr (gross)

Propane gas
22.5kW (nett), 83,450 Btu/hr (gross)

Gas flow rate

Natural gas 2.26m³/hr
Propane gas 1.75kg/hr

Pan size

Oil capacity 18L (32lbs shortening)
Width 305mm
Length 380mm
Oil frying depth 95mm

Gas connection

R 3/4 (BSP) male
40mm from RH side, 24mm from rear,
and 221mm from floor

Dimensions

Width 400mm
Depth 800mm
Height 915mm
Incl. splashback 1085mm
Nett weight
61kg

Packing data

0.53m³, 76.5kg
Width 900mm
Depth 470mm
Height 1255mm

Gas types

Available in Natural gas and Propane gas,
please specify when ordering
Other gas types on request

Supplier:-

KiD Catering Equipment
Oaktree Court Business Centre, Mill Lane
Ness, Cheshire, CH64 8TP

sales@kidcateringequipment.com

www.kidcateringequipment.com

Tel: 0333 123 2450



ISO9001
Quality
Management
Standard

Designed and manufactured by



ISO9001

All Cobra products are designed and manufactured by Moffat using the internationally recognised ISO9001 quality management system, covering design, manufacture and final inspection, ensuring consistent high quality at all times.

In line with policy to continually develop and improve its products, Moffat Limited reserves the right to change specifications and design without notice.



© Copyright Moffat Ltd
UK.C.01.19 / 1622

an Ali Group Company



The Spirit of Excellence