

## C6D

### 600mm Four Burner Gas Cooktop



C6D

- 600mm wide
- 4 open burners
- 5kW open burner rating
- Flame failure standard on open burners
- Cast iron burners and vitreous enamel potstands
- Open cabinet base for extra storage
- Adjustable front feet and rear rollers
- Stainless steel finish
- Fully modular

#### Also Available



C6B



C6C

#### OVERALL CONSTRUCTION

- Cast iron open burner heads with vitreous enamelled cast iron caps
- Vitreous enamelled potstands
- Vitreous enamelled control panel
- Stainless steel front, sides and splashback
- Stainless steel cabinet interior base
- Stainless steel spill tray
- 63mm dia. stainless steel adjustable legs to front and two rollers at rear

#### CONTROLS

- Large easy use control knobs
- Variable high to low controls to open burners
- Flame failure standard on open burners

#### CLEANING AND SERVICING

- Easy clean stainless steel exterior
- Vitreous enamelled potstands and burner caps
- Lift off open burner caps and removable burners
- Removable spill trays
- Access to all parts from front of unit

#### Matching Products



CR9D



CR6C



CF2



CR9A



CT6



C450



CP4



CS9 / C900-S



CT9

## C6D

### 600mm Four Burner Gas Cooktop

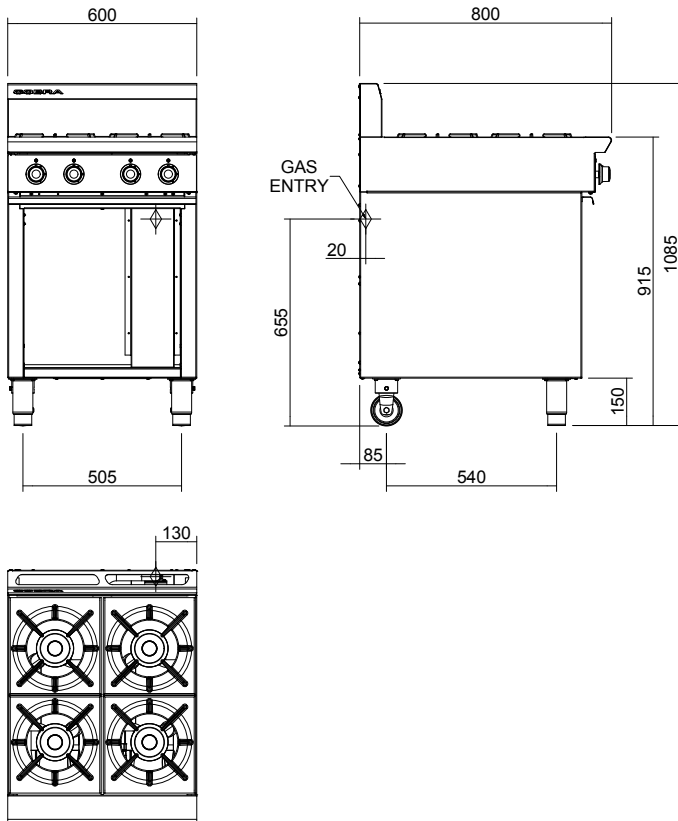

C6D

#### SPECIFICATIONS

##### Burners

Open Burners;  
Natural Gas  
5.0kW each  
Propane gas  
4.6kW each

##### Gas power

Natural gas  
20.0kW (nett), 75,790 Btu/hr (gross)  
Propane gas  
18.4kW (nett), 68,240 Btu/hr (gross)

##### Gas flow rate

Natural gas 2.12m<sup>3</sup>/hr  
Propane gas 1.44kg/hr

##### Gas connection

R 3/4 (BSP) male  
130mm from RH side, 20mm from rear, and 655mm from floor

##### Dimensions

Width 600mm  
Depth 800mm  
Height 915mm  
Incl. splashback 1085mm

##### Nett weight

68kg

##### Packing data

0.85m<sup>3</sup>, 99kg  
Width 710mm  
Depth 955mm  
Height 1250mm

##### Gas types

Available in Natural gas and Propane gas,  
please specify when ordering  
Other gas types on request

#### Supplier:-

**KiD Catering Equipment**  
Oaktree Court Business Centre  
Mill Lane, Ness, Cheshire, CH64 8TP

[sales@kidcateringequipment.com](mailto:sales@kidcateringequipment.com)

Tel: 0333 123 2450

[www.kidcateringequipment.com](http://www.kidcateringequipment.com)



ISO9001  
Quality  
Management  
Standard

Designed and manufactured by



#### ISO9001

All Cobra products are designed and manufactured by Moffat using the internationally recognised ISO9001 quality management system, covering design, manufacture and final inspection, ensuring consistent high quality at all times.

In line with policy to continually develop and improve its products, Moffat Limited reserves the right to change specifications and design without notice.



© Copyright Moffat Ltd  
UK.C.01.19 / 1622

an Ali Group Company



The Spirit of Excellence