

# Halcyon AMH55 WSD

## undercounter

### DISHWASHER

halcyon®

#### Halcyon **AMH55 WSD** Features

- **1 year warranty**
- Three button bright LED display with soft touch controls and alarms menu
- Automatic continuous water softener, breaktank & drain pump as standard
- Accurate detergent and rinse aid peristaltic dosing pumps
- Dosing set up by fascia controls
- Easy clean parallel wash and rinse arm assembly
- Optional surface scrap tray filters



Supplied with one pegged (capable of holding 18 10" plates), one open rack (capable of holding 25 pint glasses) and cutlery insert.

Additional racks can be purchased

#### Distributor:

**KiD Catering Equipment, Oaktree Court Business Centre, Mill Lane, Ness, Cheshire, CH64 8TP**  
Tel: 0333 123 2450

[sales@kidcateringequipment.com](mailto:sales@kidcateringequipment.com)

# Halcyon AMH55 WSD

## undercounter DISHWASHER



### Technical Data

Dimensions (W x D x H)	mm	580 x 610 x 810	Wash tank element	kW	2.1
		+ Feet	Boiler element	kW	6.0
Feet height	mm	10-20	Wash pump	kW	0.47
Rack size	mm	500 x 500	Tank capacity	L	20
Maximum useable height	mm	340	Noise emission	dB	≤ 55
Door opening	mm	365	<b>Packaging Specs</b>		
Theoretical productivity	Racks/h	40	Gross weight	Kg	70
Effective productivity	Racks/h	30*	Cubic volume	m <sup>3</sup>	0.45
			Dim. (W x D x H)	mm	670 x 690 x 980

\*Allowing 30 seconds for reloading  
Cycle times may vary depending on local conditions/services

### Installation Diagram – All services must be within 1 meter

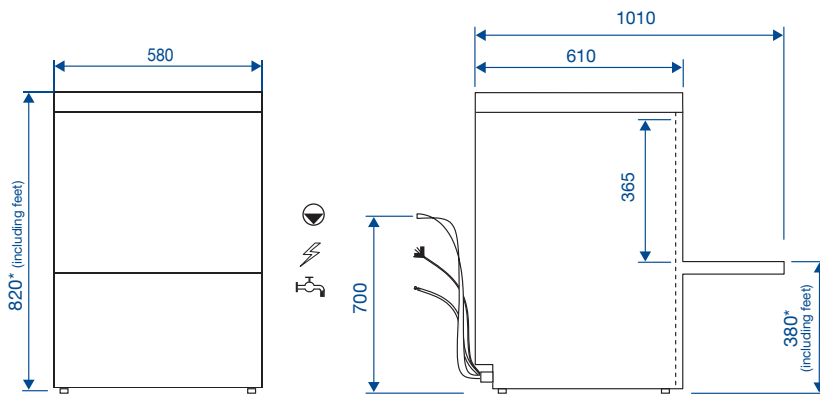

\*Height-adjustable feet + 10mm

### Power Supply

Installed power	AMP	KW
230V – 50Hz – 1N	13	2.6
	20	4.5
	30*	6.5
Optional 3 Phase config	Total load 6.5kW	
Fused	16 amp	

\*Standard configuration

**Pumped waste into upstand, maximum height 700mm**

**Power**  
**Water supply 2 – 4 bar**

### Water Connection

Inlet water pressure	Bar	2 to 4
Flow rate L/Min	L/Min	6
Water inlet temp	°C	10 to 50
Water connection	BSP	¾"
Waste connection	Ø	Int 19/ext 24

### Cycle Information

Number of standard cycles		2
Standard cycles times	Sec	90/180
Special cycle		Long
Self-cleaning cycle		Full self clean
Water consumption per cycle	L	2.5
Wash temperature	°C	60 – adjustable
Rinse temperature	°C	82 – adjustable

#### Distributor:

**KiD Catering Equipment, Oaktree Court Business Centre, Mill Lane, Ness, Cheshire, CH64 8TP**  
Tel: 0333 123 2450

**sales@kidcateringequipment.com**