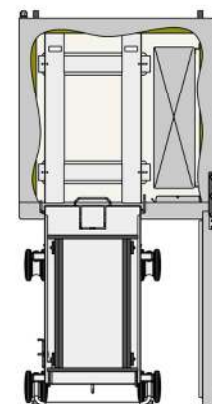
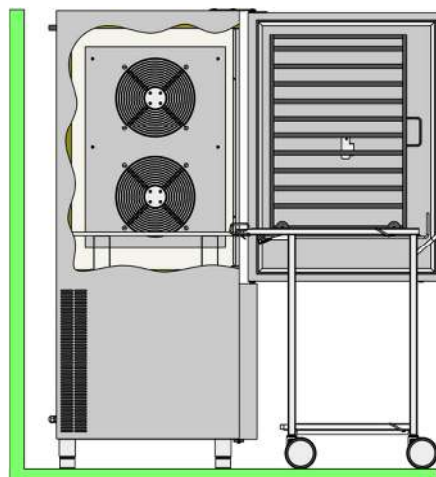

EVOX 10 50kg Lengthwise / for mobile rack

TECHNICAL FEATURES

Model	Performance		Capacity in Trays	Standard Tension	Power Consumption	Refrigerant
	(+90°C/+3°C)	(+90°C/-18°C)				
SQX10FT.50L	50 kg	30 kg	10-15 GN 1/1 10-15 EN 60x40	400V / 3Ph+N 50Hz	3,5 kW 11,0 A	R404A 2,000 kg
SQX10FT.50LW						
SQX10FT.50LR						
SQX10FT.50LWR						
SQX10FT.50LSG	/	/		400V / 3Ph+N (230V / 1Ph+N*) 50Hz	0,5 kW 1,5 A	R404A 0,000 kg
SQX10FT.50LSGCO ₂						CO ₂ 0,000 kg

* Optional

CONSTRUCTIVE FEATURES

	STRUCTURE IN STAINLESS STEEL AISI 304 18/10 – EXTERNAL: SCOTCH BRITE, INTERIOR: MIRROR FINISHING		ROUNDED INNER AND OUTER ANGLES CLEANING AND SPACE UNDER THE EVAPORATOR FOR A PERFECT AND EASY CLEANING
	CERTIFIED ITALIAN HIGH PERFORMANCES REFRIGERATING UNITS		OVERSIZED CONDENSERS TO ENSURE RELIABILITY
	SPECIAL FANS SUITABLE FOR LOW TEMPERATURE WITH SPEED REGULATION SYSTEM		CATAPHORESIS PAINTED ANTI-CORROSION EVAPORATORS

Structure insulation in CFC-free polyurethane DPO-0 - Door frame completely integrated in the structure itself to grant top hygiene - Self-closing door equipped with a silicone gasket resistant to low temperatures, magnetic and heated door frame - Core probe with strong silicone gum grip as standard - Lateral drain hole for condensation and water run out - The technical room of evaporator and condenser can be easily inspected through a compass opening

The appliance is supplied without trays, without trolley, ramp and without mobile oven racks. CO₂ versions are supplied without thermic expansion valve. The manufacturer reserves the right to carry out modifications of the product without notice. For different voltages and/or frequencies quotations on demand.

INNER AND OUTER DIMENSIONS

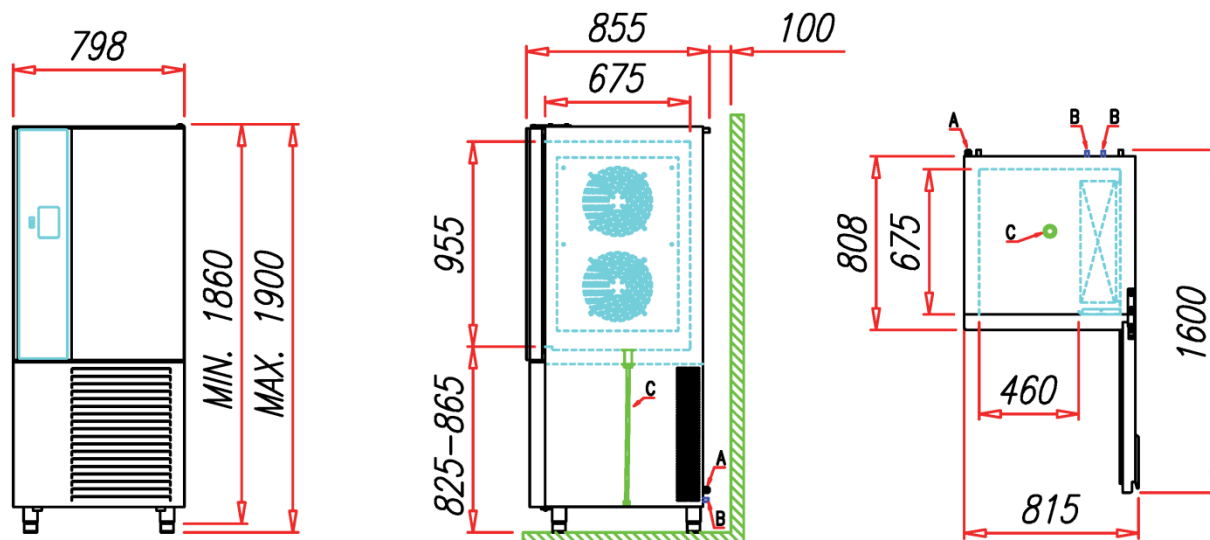

A = Electrical and Water connection (when needed)
 B = Refrigeration connection
 C = Evaporator water drain pipe

TECHNICAL DATA

Model	Refrigerating Power		Consumption kWh/kg		Net Weight	Insulation Thickness	Room Conditions	Certifications
	*Te = -10°C	*Te = -30°C	(+90°C/+3°C)	(+90°C/-18°C)				
SQX10FT.50L	7.920 W	2.700 W	0,11	0,33	220 kg	70 mm	+32°C 60% UR	CE
SQX10FT.50LW								
SQX10FT.50LR								
SQX10FT.50LWR								
SQX10FT.50LSG								
SQX10FT.50LSGCO ₂	/	/	/	/	140 kg			

* Te = Expansion Temperature – Condensation Temperature = +45°C

ELECTRONIC CONTROLLER

Cycles available:

- Temperature blast chilling and conservation
- Time blast chilling and conservation
- Temperature deep freezing and conservation
- Time deep freezing and conservation
- Soft and hard cycles for both blast chilling and deep freezing
- Multi timer non-stop cycle
- Pre-cooling

Optional cycles:

- Multi core probe non-stop cycle
- Sterilization
- Leavening/proving
- Low temperature slow cooking



Special functions:











- Recipe book
- Automatic control on core probe insertion
- raw fish sanitation
- Thawing
- Manual defrost
- Special cycle for ice cream
- Drying
- Evaporator fan speed regulation
- USB

Optional functions:

- Core probe heating
- Multipoint core probe
- Multi core probe

The appliance is supplied without trays, without trolley, ramp and without mobile oven racks. CO₂ versions are supplied without thermic expansion valve. The manufacturer reserves the right to carry out modifications of the product without notice. For different voltages and/or frequencies quotations on demand.

ACCESSORIES (OPTIONAL)

	Leavening and Slow cooking	ACC FO3		Led light	ACC 148
	Kit 4 Castors	ACC 141		Left opening door	ACC 135
	Ozone Sterilizer	ACC 110		Heated Core Probe	ACC 509
	Multipoint core probe	ACC 510		Trolley	ACC 171
	Removable tray structure 10 GN 1/1	ACC 162		Removable tray structure 10 EN 60x40	ACC 164

DATA SHEET ACCORDING TO prEN 17032

Model	Product Type	Refrigerating Gas			Program	
		Type	GWP	Charge	Blast Chilling	Deep Freezing
SQX10FT.50L	BLAST CHILLER DEEP FREEZER	R404A	3922	2,000 kg	HARD	TEMPO
SQX10FT.50LW						
SQX10FT.50LR						
SQX10FT.50LWR						
SQX10FT.50LSG						
SQX10FT.50LSGCO ₂		CO ₂	1	0,000 kg	/	/

Model	Blast Chilling (+65°C / +10°C)			Deep Freezing (+65°C / -18°C)		
	Maximum Capacity	Energy Consumption E	Time t	Maximum Capacity	Energy Consumption E	Time t
SQX10FT.50L	50 kg	0,11 kWh/kg	120 min.	30 kg	0,33 kWh/kg	260 min.
SQX10FT.50LW						
SQX10FT.50LR						
SQX10FT.50LWR						
SQX10FT.50LSG	/	/	/	/	/	/
SQX10FT.50LSGCO ₂	/	/	/	/	/	/

Manufacturer: A.T.O. S.R.L. - Via dell'Artigianato, 24 - 31030 Castello di Godego - Treviso – Italy

STANDARD PACKAGE

Package	External Dimensions			m ³	Gross Weight	
	Width	Depth	Height		Standard	SG Version
1	890 mm	950 mm	2060 mm	1,74	255 kg	175 kg

 The appliance is supplied without trays, without trolley, ramp and without mobile oven racks. CO₂ versions are supplied without thermic expansion valve. The manufacturer reserves the right to carry out modifications of the product without notice. For different voltages and/or frequencies quotations on demand.